

Installation manual v2

# Sprint Track

20 meter

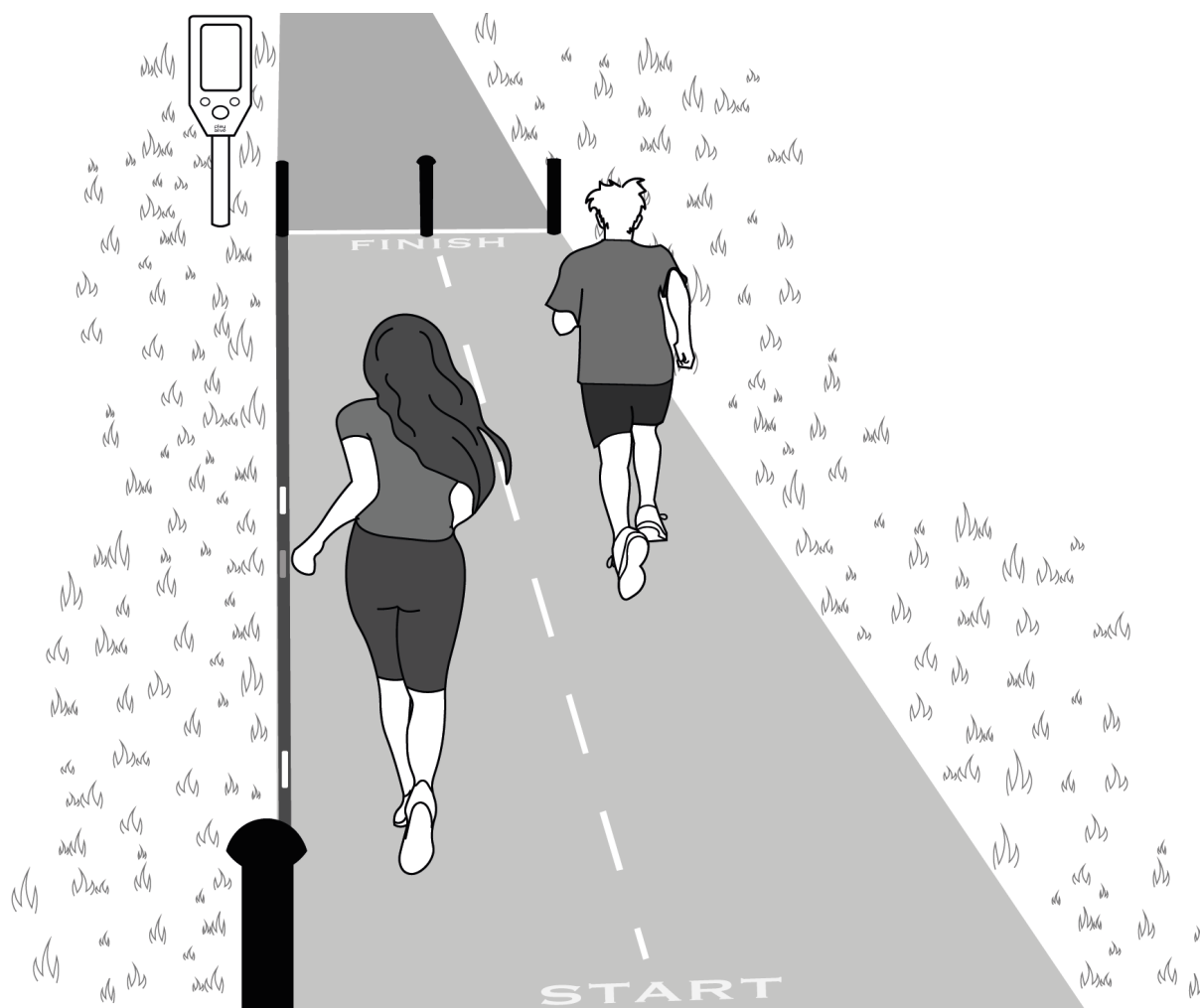

play<sup>®</sup>  
alive

## **1. Content**

## **2. Component overview**

- 2.1 Steel/aluminium elements & pre-installed electronics
- 2.2 Other elements

## **3. Site of construction**

- 3.1 Overview
- 3.2 Installation of steel poles
- 3.3 Pulling of Devicenet cables
- 3.4 Cable from display unit
- 3.5 Connecting the aluminium rails

## **4. Aligning the steel posts on the finish line**

- 4.0 Aligning the steel posts

## **5. Start UP**

- 5.1 Turn the system on
- 5.2 Start an activity and test the setup

## **6. Activities on the Sprint track**

- 6.0 Activities

## **7. Appendix**

- 7.1 General introduction to PlayAlives Technology Platform
- 7.2 Conduit pipes and PlayAlive technology

## 2.1 Steel/aluminium elements & pre-installed electronics



1x Display Unit



1 x Steel unit /w  
Sensor and Satellite



1 x Steel unit /w  
Satellite



1 x Steel unit /w  
Reflector - High



1 x Steel unit /w  
Reflector - Low



4x Aluminium Top Rail with LED Modules



4x Aluminium Bottom Rail

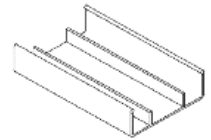

Aluminium Rail  
Connectors

## 2.2 Other elements

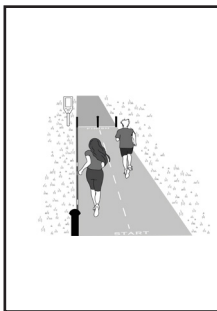

1x Installation Manual



3x Devicenet Cables



1x Pigtail cable  
(for connecting display with 240V )

# 3

## Site of construction

### 3.1 Overview

Assess based on local conditions which measurements are best for your sprint track. However, the delivered PlayAlive cables and the programming is based on the listed measurements on the rendering.

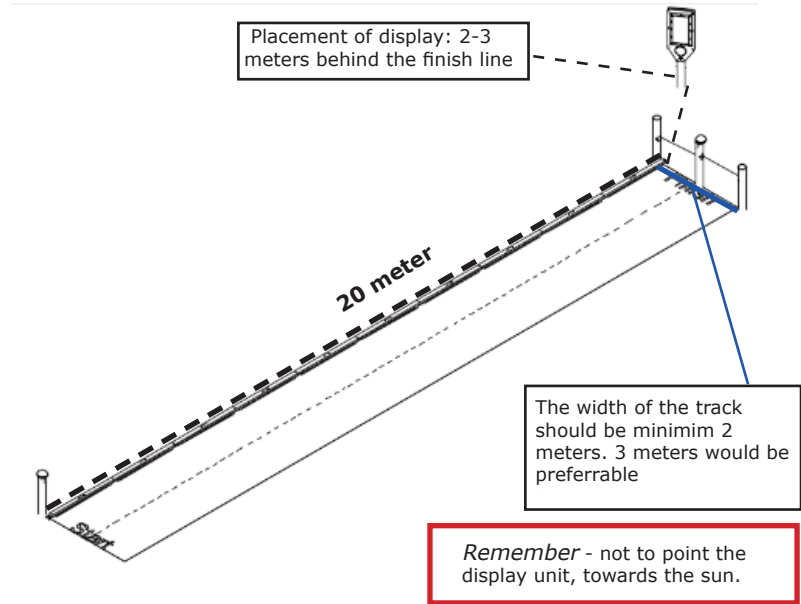

### 3.2 Installation of steel units

All Steel unit must be installed in the ground as shown in the example below. This includes the display unit.

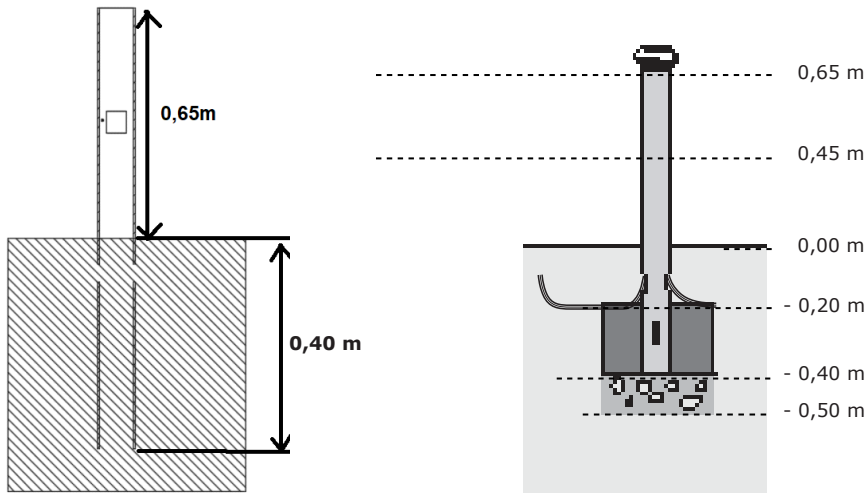

**Important:** All steel units must be placed so they are leveled and plumbed. Please use a leveler to assist you on this task.

**Please do not CAST the steel units before you have completet point 5.2**

### 3.3 Pulling of Devicenet cables

Below is a schematic of the general wiring route.

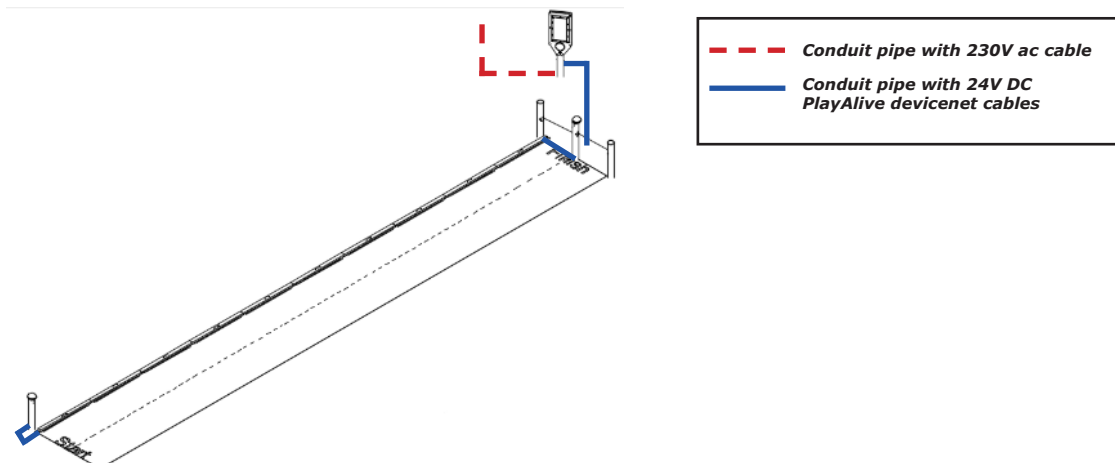

### 3.4 Cable from display unit

**Step 1** - Please start by supply 230 V power cable to the PlayAlive display unit. Please plug in the power connector at the bottom of the PlayAlive display (see picture below). Connect the PlayAlive cable with the power cable pulled to the display unit. This work needs to be done by an electrician.

An electrician brings the standard installation cable to the PlayAlive steel post where the display is mounted. The following are used:  
3 x 1.5 mm<sup>2</sup> pvikj installation cable. This cable must be connected with the supplied PlayAlive "Pig-tail" Cable. Important the installation is grounded.

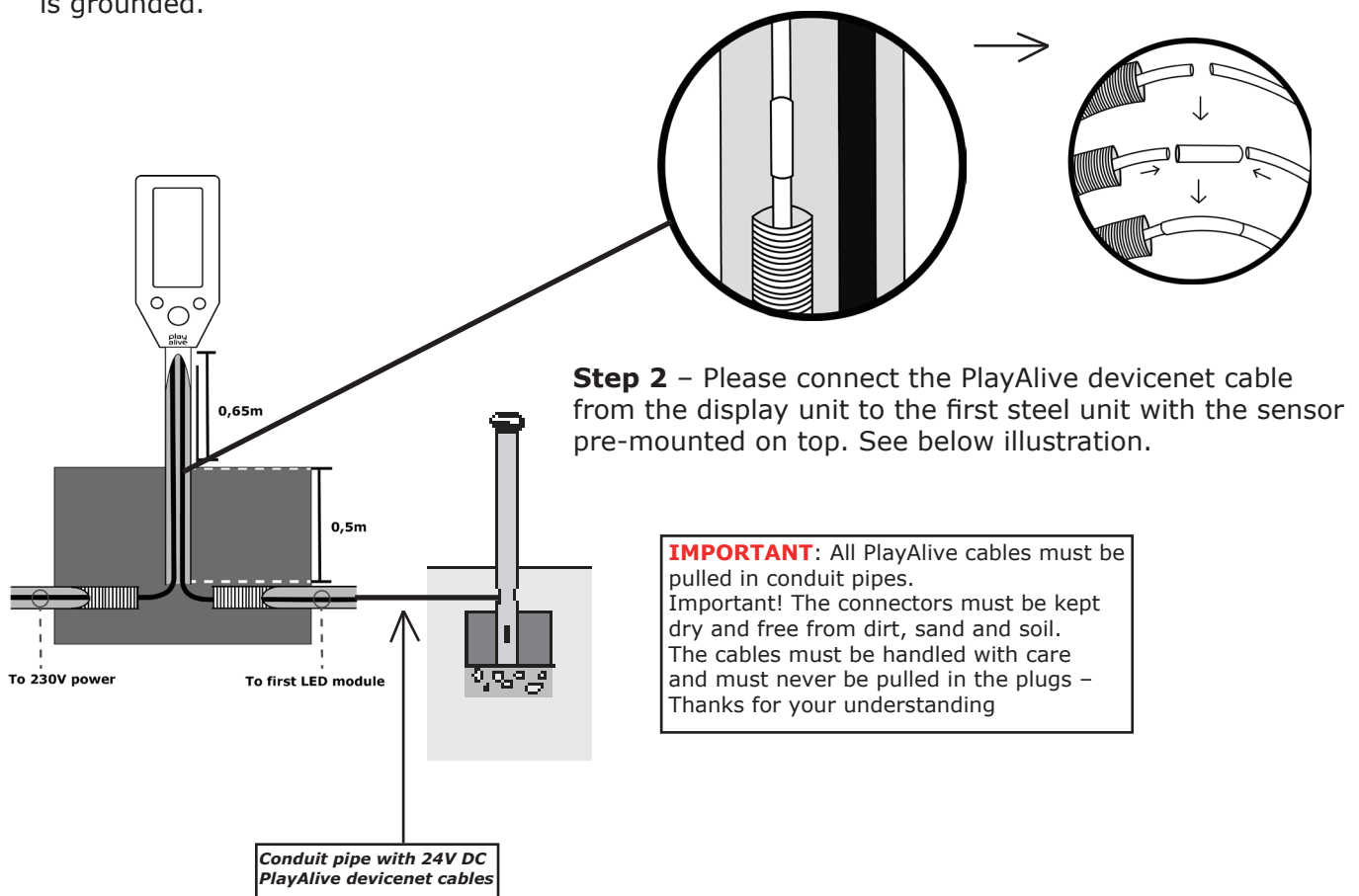

**Step 3** – Please connect the cable from the steel tube to the aluminium rail. See illustration below on how to connect the cable.

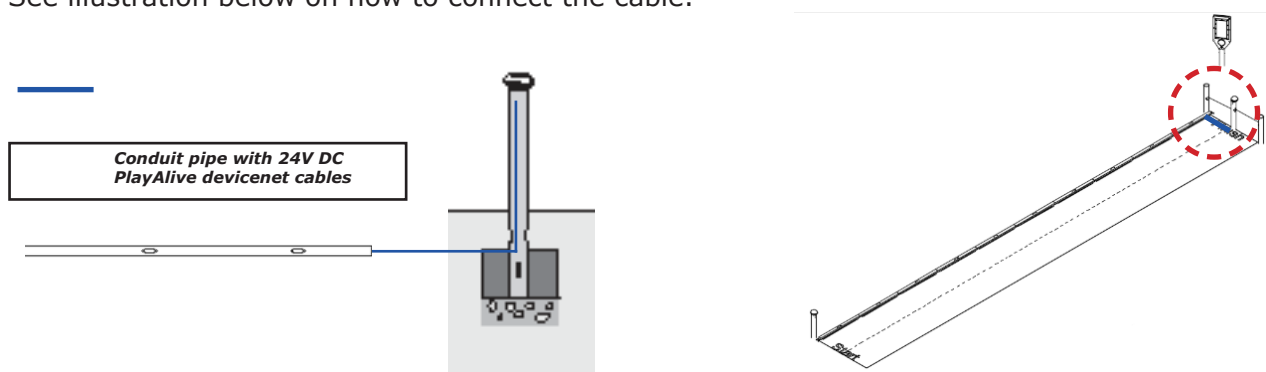

### 3 Site of construction

#### 3.5 Connecting the aluminium rails



Please note that all cables in the aluminium rail come with gel applied.



Please connect the connectors inside the aluminium rails (see picture)

#### 3.6 Devicenet Cable to PlayAlive sensor

Connect the last devicenet cable from the aluminium rail to the steel tube with the PlayAlive sensor on top. When installed this devicenet cable the wiring route has been completed.

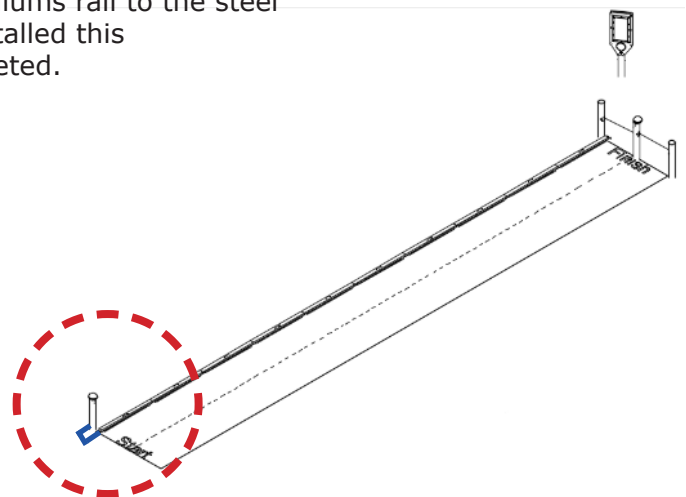
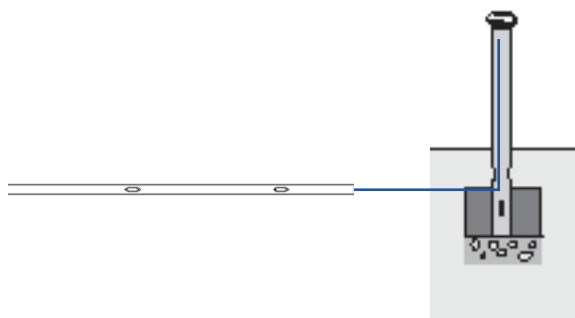

### 4 Aligning the steel posts on the finish line

#### 4.0 Aligning the steel posts

Before casting the remaining steel units (See below marked with **red**) for the finish line it is important to note the middle pillar has two photosensors. Those two sensors must be placed facing directly at a reflector at the same height.

All steel posts that need to have the same line position on the sprint track. It's important as the photosensors need to point directly towards the reflectors in order to work as intended

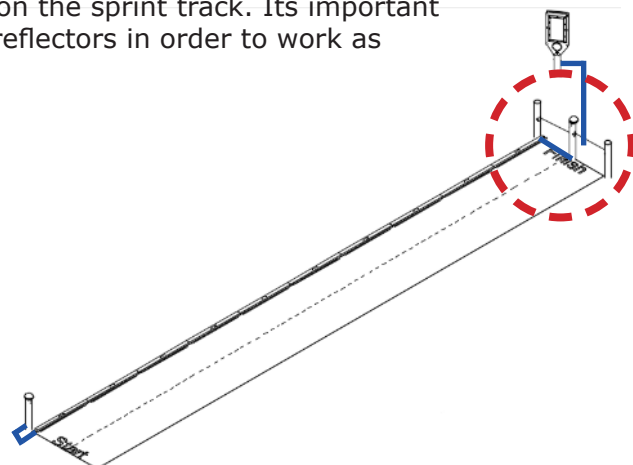

Please note the line in the middle is the alignment line and the sensors should be pointing along that line into a reflector.

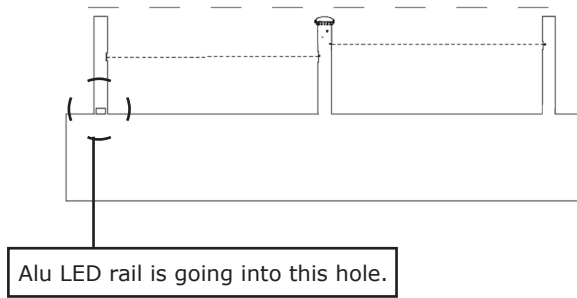

**Important:** All steel units must be placed so they are leveled and plumbed. Please use a leveler to assist you on this task.

**Important:** Please turn on the system and make sure that all work as intended before you start to **cast** the steel posts.

## 5 Start UP

### 5.1 Turn the system on

Turn the power on. The system now starts up. After 4-5 minutes the display will light up and the system is now ready for you to select an activity

### 5.2 Start an activity and test the setup

Select and start an activity. Go to the display and select an activity. Select "Sprint". When crossing the finish line, Please make sure that the time stops immediately for each lane.

If this is not the case, please check the alignment of the Steel posts and see point 4.0. If everything is now working as intended, please go ahead and cast the steel units placed at the finish line.

## 6 Activities on the Sprint track

### 6.0 Activities

- Beep-test
- Sprint
- Race against animals

Please bear in mind that the system is online and new activities can easily be uploaded by PlayAlive Denmark. Please, do not hesitate to contact if questions occur.

## PlayAlive A/S

Jens Grøns Vej 2 7100 Vejle, Denmark  
Phone: +45 2750 6400 or +45 2048 1055

[www.playalive.dk](http://www.playalive.dk)

## 7.1 General introduction to PlayAlives Technology Platform

The PlayAlive system is an interactive system. The technology elements communicate with each other and thereby make it possible to realize activities for all ages. The visible part of the installation is the "satellites" and the display unit. The satellites are intelligent units that contain light, sound, touch sensor, and communication. They act as the user interface to the system. Cables connected to satellites supply them with power and communication.

**IMPORTANT: BE CAREFUL WHEN HANDLING THE PARTS.**

The PlayAlive technology elements are highly advanced electronics. Despite the fact that they are very robust after installation, they can easily be damaged before or during installation if not treated correctly.

**NOTE: ALL PARTS ARE DESIGNED TO FIT TOGETHER WITHOUT THE NEED OF USING FORCE.**

## 7.2 Conduit pipes and PlayAlive technology

When using flexible cable pipes, it is important to ensure that the minimum bending radius complies too the following:

For our device net cables, we recommend 28/34 mm flexible cable pipe / conduit pipe with double walls for easy pulling of the cables.

Please note that low-cost cable pipes are very soft and therefore very easy to bend in inappropriate radiuses – they are not recommended!

It is further recommended to place covers over the ends of the cable pipes during the period from installation of the pipes to installation of the electronics to avoid water in the pipes.

When installing the cable pipes, it is recommended to ensure that care is taken to ensure that the pulling string in the pipes are kept available. It makes pulling the cables a lot easier. If this is not possible, then we recommend that you use vacuum (ex. a vacuum cleaner) to suck a pulling string through. It has proven easier than other methods.

In some cases, it is possible to push the cable through the pipes without other help. In cases where this is not possible, it is recommended to use a pulling string.

Please be aware that the PlayAlive cables are not designed to be pulled in the connectors. When pulling the cables please make sure that you pull the cable and not the connector.