

Installation manual v2

Infinity

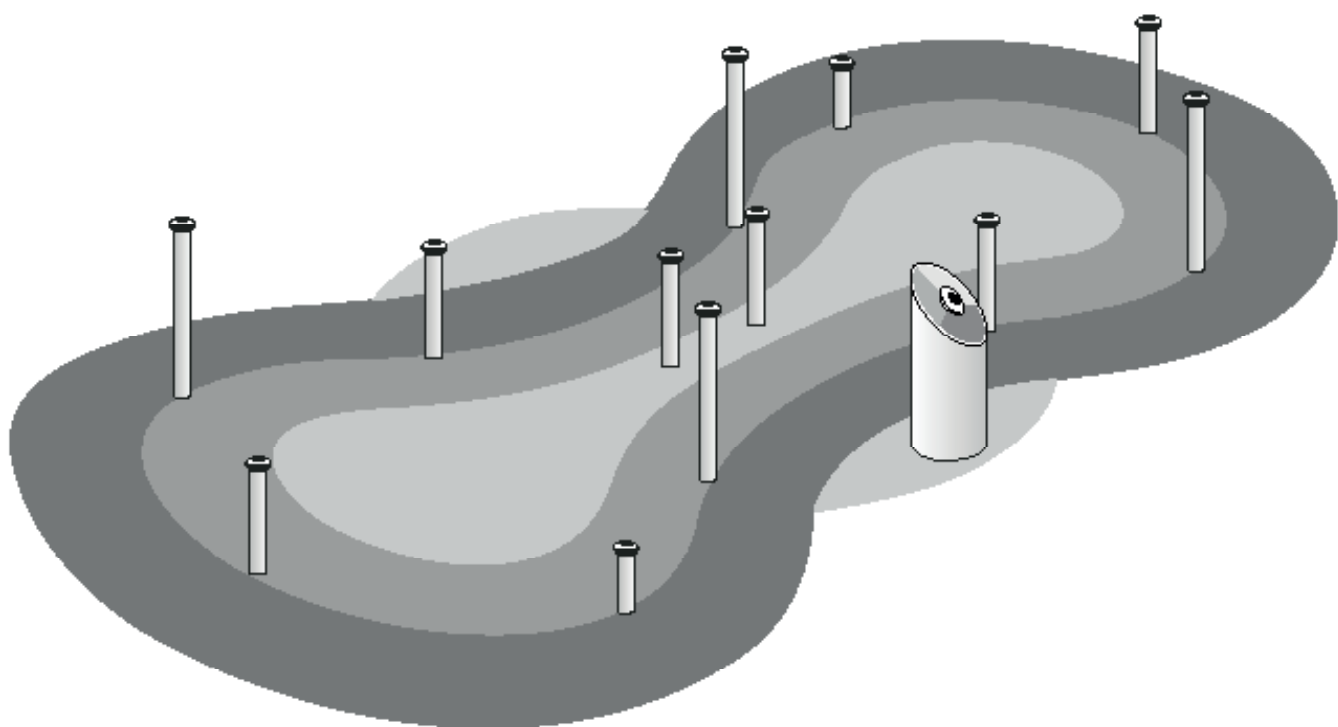

play[®]
alive

1. Content

2. Component overview

- 2.1 Electronics
- 2.2 Steel components
- 2.3 Other

3. Site of construction

- 3.1 Maximum length of power cable
- 3.2 Correct placement of steel poles and console

4. Game selector console

- 4.1 Installing the console

5. Conduit pipes

- 5.1 Placement of conduit pipes & cables
- 5.2 Correct bending of conduit pipes
- 5.3 Pulling cables

6. The circle sign

- 6.1 Mounting the circle sign

7. Installing satellites in steel poles

- 7.1 Satellites ID's
- 7.2 Installing each satellite
- 7.3 Installing the termination plug
- 7.4 Fix satellites with screws

8. Installing the power supply

9. Start up

- 9.1 Start up the system
- 9.2 Select Game
- 9.3 Reset the Game
- 9.4 Idle mode
- 9.5 Adjust Volume

10. Appendix

- 10.1 General introduction to PlayAlives Technology Platform
- 10.2 Conduit pipes and PlayAlive technology
- 10.3 Games

11. Platform specification and maintenance

- 11.1 Electrical specifications
- 11.2 Average daily power consumption for full system
- 11.3 Maintenance

2

Component overview

2.1 Electronics

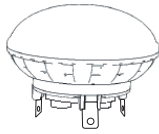

13 x Splitter Satellite
P00250



1 x Devicenet Cable
3.5 m (yellow)
P00255



11 x Devicenet Cable
5.5 m (purple)
P00256



1 x Devicenet Cable
33 m (blue)
P00257

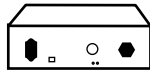

1 x Power supply
(IPSU)
P00251



1 x Termination Plug
(devicenet)
P00252

2.2 Steel components



4 x Stainless steel poles
85 cm o. ground



6 x Stainless steel poles
65 cm o. ground



2 x Stainless steel poles
45 cm o. ground



1 x Steel console
(powder coated)

2.3 Other



1 x Sign
for Steel console
(either sourced locally or by PlayAlive)



**3 x Dual adhesive tape
or male/female velcro**
(for Sign)

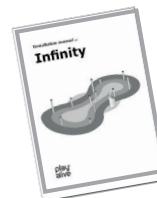

Installation manual
(this copy)



1 x Bit TX 25 x 25 MB



39 x M5 Countersunk
16 mm A2

3

Site of construction

3.1 Maximum length of power cable

Distance between power supply and the Infinity console must not exceed 33 m.

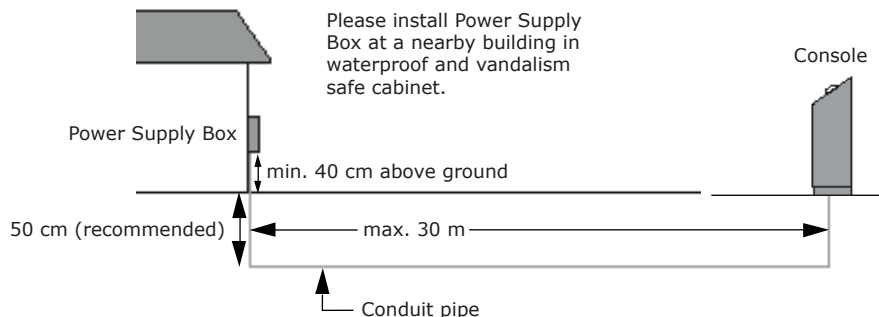

Important!

Remember pull wire in conduit pipe. Conduit pipe needs to be sourced locally.

3.2 Correct placement of steel poles and console

Please follow the measures below when positioning the steel poles.

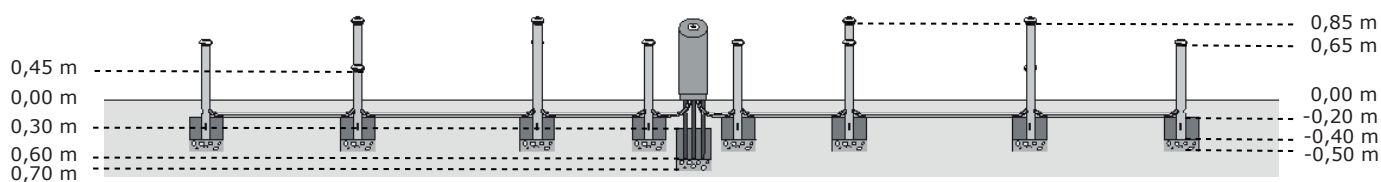
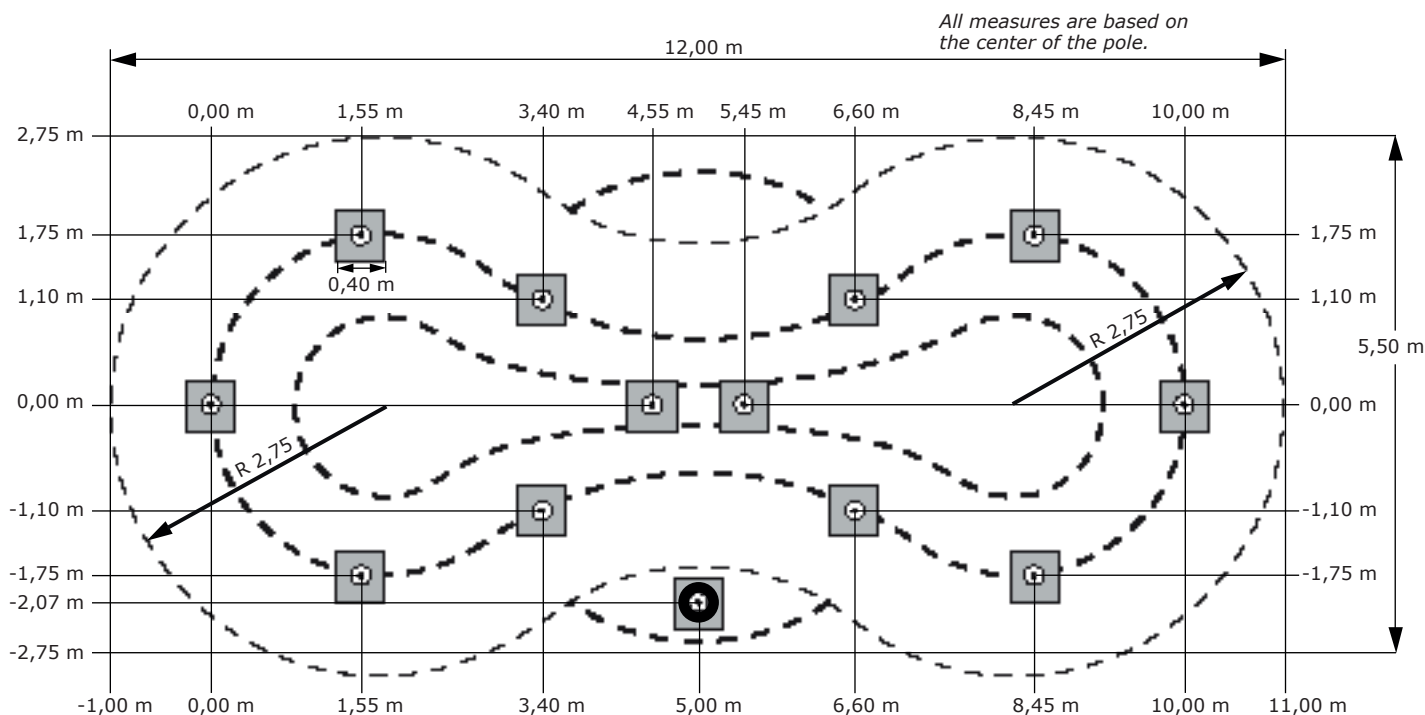

4.1 Installing the console

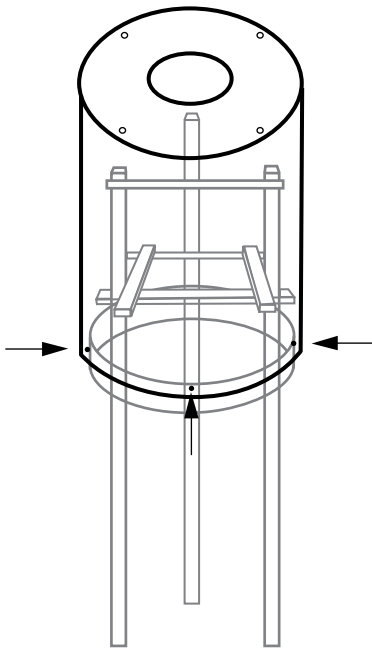

1. Separate the console from its casting legs by removing the 4 screws at the bottom of the console. (The top cover is reinstalled after casting and cable pulling.)
2. Follow the instruction on correct placement of console. See illustrations in section 3.2 *Correct placement of steel poles and console*.
3. After casting all steel poles and console legs. Place the conduit pipes see section 5 *Conduit pipes*.
4. Use pull wire in the conduit pipes to draw cables.
5. In order to avoid moisture from the ground, please seal off the consoles connection to the ground. See illustration below.
6. Reinstall the top cover of the console, and fasten it at the bottom with the 4 screws.
7. Install the satellite with ID 0, when mounting the sign, please read section 6 *The Circle Sign* before installing the satellite.

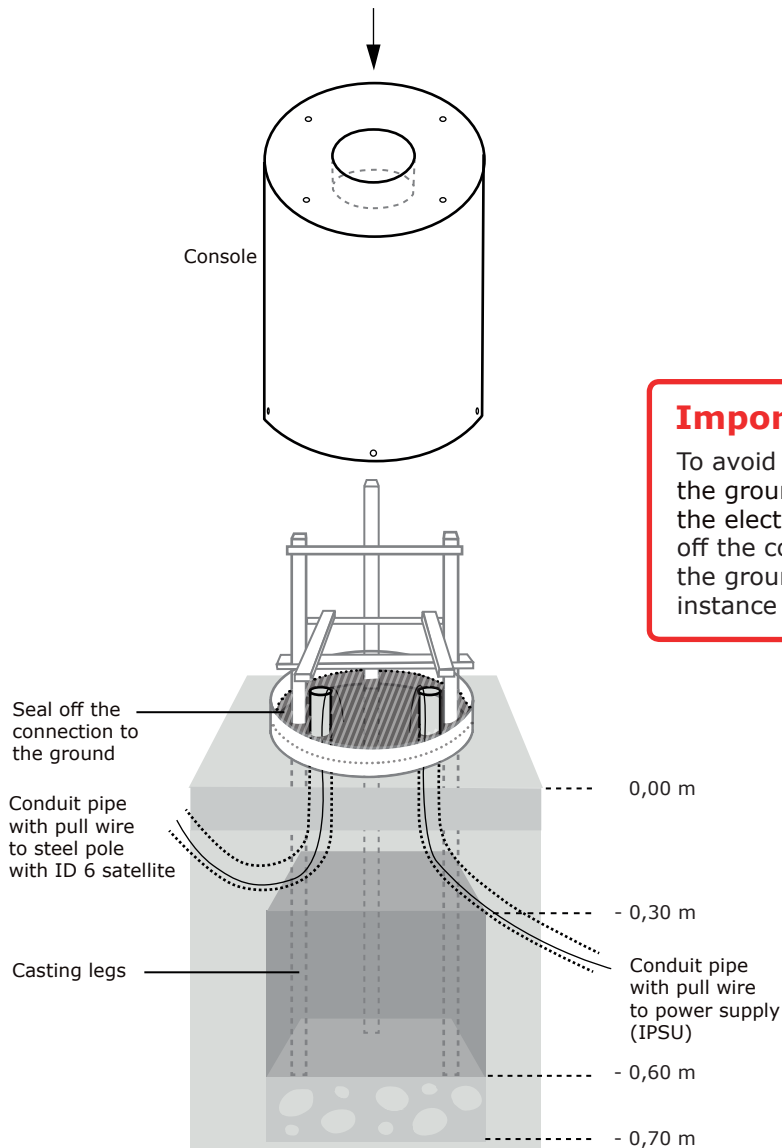

Important!

To avoid moisture from the ground damaging the electronics seal off the connection to the ground with for instance wet pour.

5.1 Placement of conduit pipes & cables

Cables must be placed in conduit pipes between steel poles. How to place the pipes are given below:

Important!

Please read the **appendix section 10.2** for further instruction on how to handle conduit pipes in combination with PlayAlive cables.

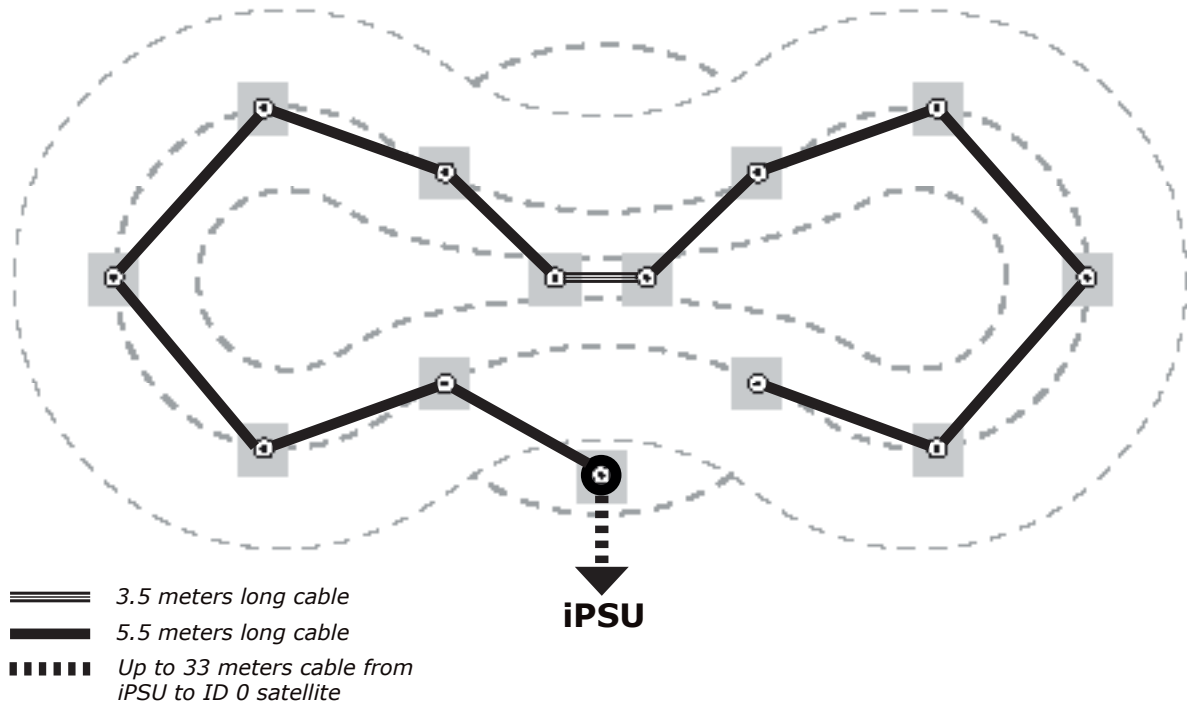

5.2 Correct bending of conduit pipes

The illustration shows the correct bending radius when the cable placed in conduit pipes goes from the ground to the steel pole. To ensure easy passage of cable.

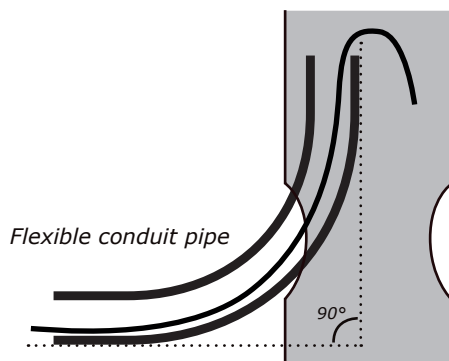

Bend carefully with a soft curve

Important!

Make sure the conduit pipes are clean. It will ease the maintaining, if at some point it should be necessary to change a cable.

5.3 Pulling cables

Pull all cables in the conduit pipes. Please be careful when pulling the PlayAlive cables.

6.1 Mounting the circle sign

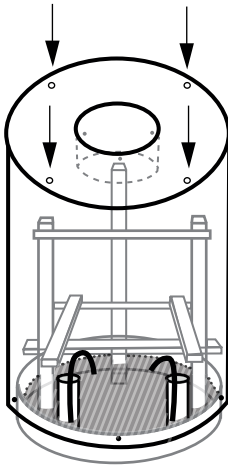

1. Loosen the top cover by the 4 screws. Remember what is top and bottom of the top cover! It is important to face it correctly when mounting it again!
2. Mount dual adhesive tape to the back-side of the sign.
3. Draw the cables through the top cover and sign center holes and connect them to the **ID 0** satellite.
4. Fasten the satellite to the top cover with 3 screws.
5. Before sticking the sign and top cover together, the top cover needs to be fastened to the Console again with the 4 screws.
6. Carefully adjust the sign to the top cover, check with the select game mode that it is correctly placed before applying pressure to the sign.

Tip:

Draw a small mark on what is top and bottom of the top cover, for correct remounting.

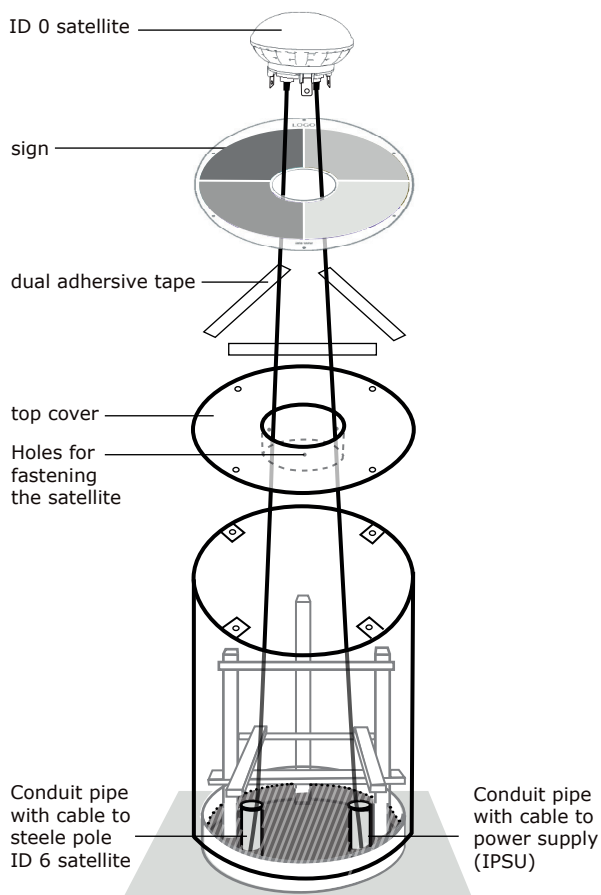

Important!

Adjusting the sign. Please check this at the end of installation **when power is on**. The sign needs to fit to the toggling colors of the satellite.

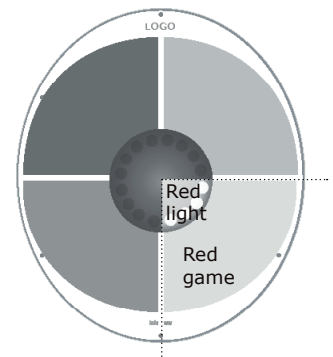

7.1 Satellite ID's

Each satellite has an individual ID, shown on a label at the rear of the satellite. Please make sure that each satellite is placed correctly as illustrated.

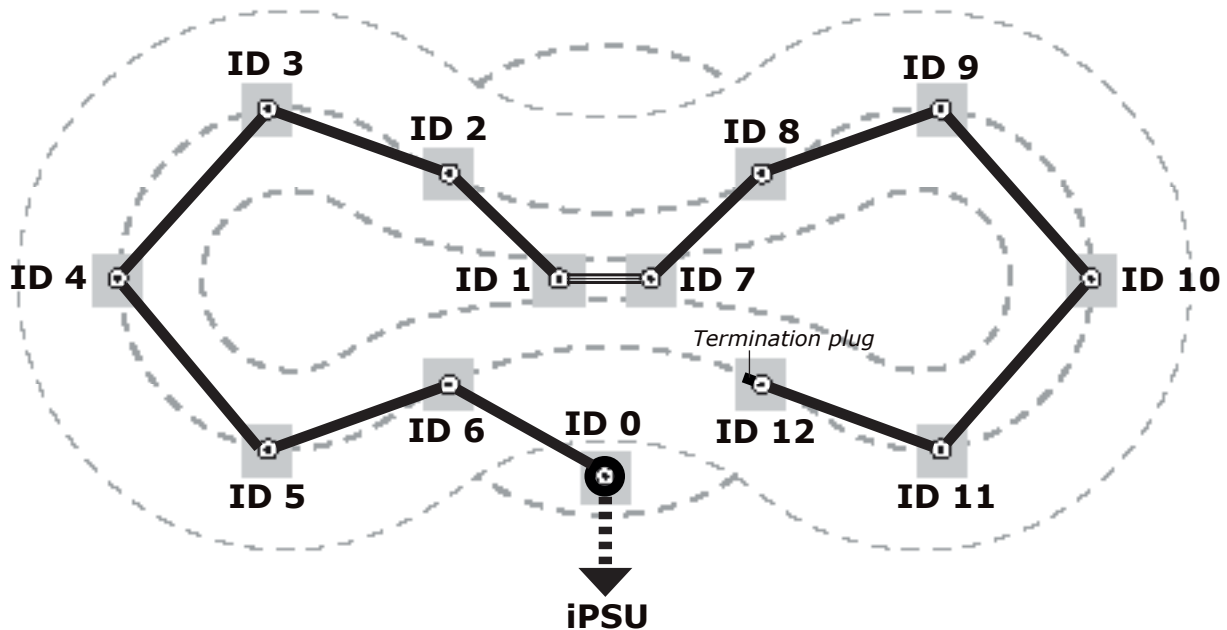

Important!

Correct placement of the satellites is needed in order for the games to work as intended! For example **ID 0** is the satellite where you select games and must be installed at the game-selector console.

7.2 Installing each satellite

Connect the pulled cables to each satellite. The cables cannot be installed wrong as they only fit to the connector one way.

7.3 Installing the termination plug

Insert the termination plug in the **ID 12** satellite.

This plug ends the communication flow between the satellites. Without this plug inserted the installation will not work properly.

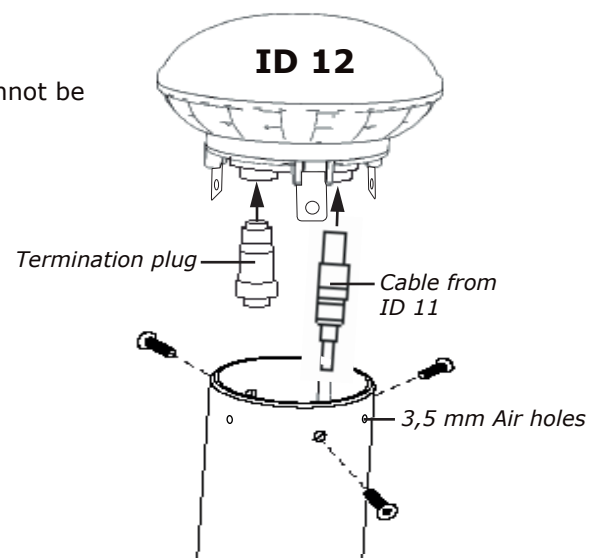

7.4 Fix satellites with screws

The satellites must be fixed to the poles with 3 screws. The holes on the poles are placed asymmetrically to ensure correct orientation.

However it would be advisable to wait and first fix the screws at the very end after you had completed the small startup tests.

Important!

Steel poles have 3,5 mm air holes near the top. Please make sure they are clear! They enable potential moisture to leave the poles.

8

Installing the power supply

The power supply (iPSU) must be placed in a **dry area**. It has been designed for outdoor temperatures, but should not be exposed to direct water (rain or water spray).

Recommended placement is inside a nearby building or in a vandal proof metal cabinet placed near the playground. A standard 110V / 230V power outlet must be available or installed.

Typical specifications for the cabinet:

Dimensions: 400 x 400 x 250 mm (Power supply dimensions: 263 x 183 x 91 mm).
 Vandalism proof metal cabinet with at least 1 key lock.
 At least 1 (preferable 2-3) socket(s) with ground installed in the cabinet.

Important!

Power and cabinet installation must be handled by an electrician.

Optional: A timer controlling the electricity (power on/off) can be added to the cabinet. Please see illustration of standard timer that can be installed in a 110 V/230 V power outlet. The timer need to be sourced locally. When applying a timer the power can be switched off for example at night time.

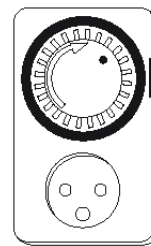

The optional timer could look like this.

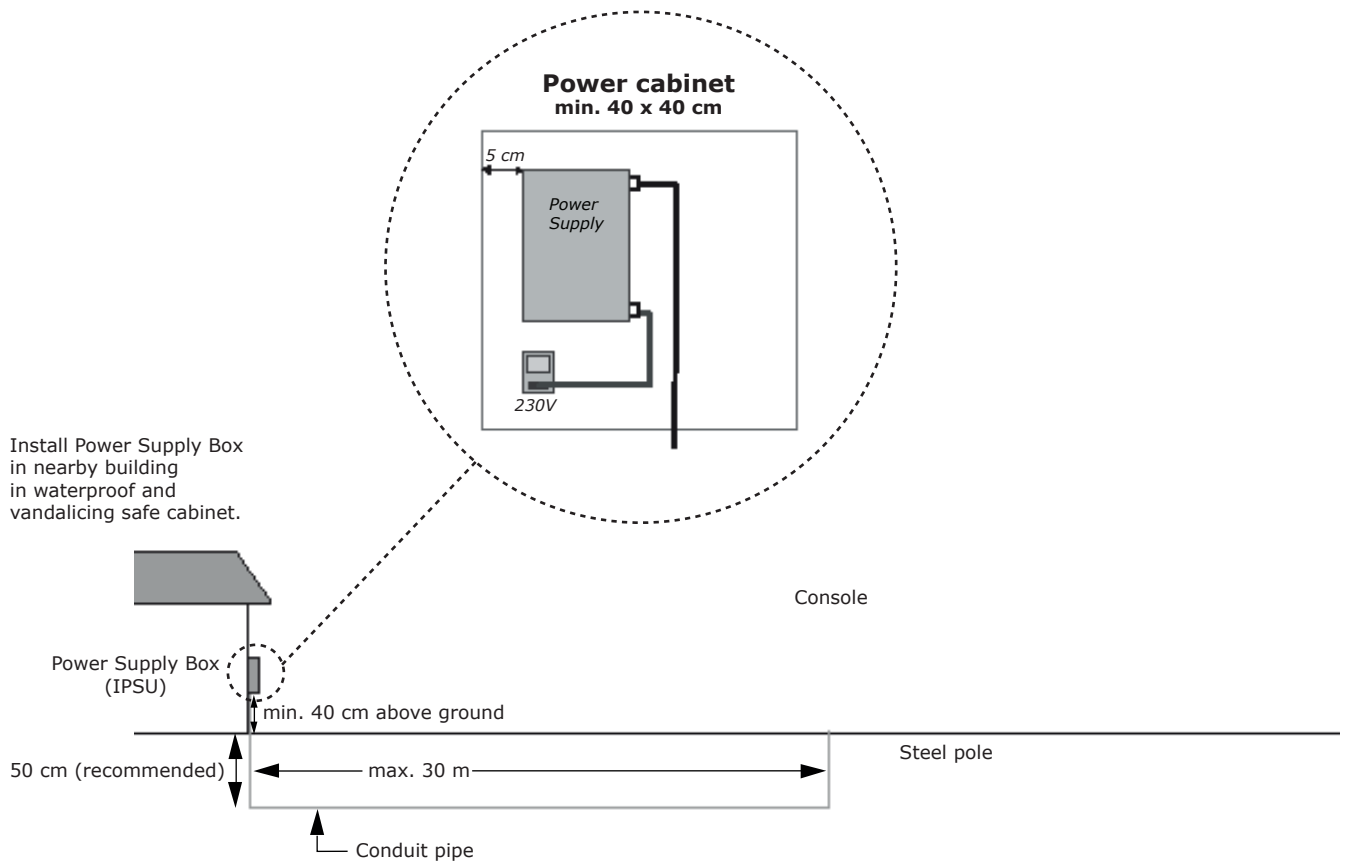

9.1 Start up the system

Turn the power on at the IPSU. The satellites boot up and after few minutes the power supply box should indicate two green lights. The system is now ready to play.

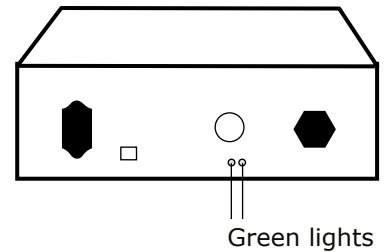

9.2 Select Game

Go to the console where satellite 0 is installed. Please select a game by touching the satellite. The satellite toggles between 4 different colors. When the satellites indicate the yellow color it indicates that you can choose the game E-tennis. See more at section 10.3 Games.

9.3 Reset the Game

Touch the satellite 0 for 5 seconds and you will reset your current game and be able to select a new game.

9.4 Idle mode

In idle mode all satellites lights up individually and can be used individually. This mode is often a hit for minor children and designed to create awareness.

The platform will go in idle mode if games are not selected. The system will turn off and only wake up every now and then and show colors to attract attention. Touching any satellite will bring the system back and you will be able to select games at the select game console.

9.5 Adjust Volume if needed

To adjust the volume, follow this procedure:

1. Turn off power
2. Wait 5 seconds
3. Turn on power
4. Wait for the select game menu to appear (switching between different colors)
5. Select a game for example e-tennis.
6. When the game is on please touch and hold satellite 0 until the satellite speak: "Set volume" – then release satellite.
7. Touch/tap satellite 0 repeatedly to adjust the volume
8. Volume adjustments are automatically saved and will remain at this level until you adjust it again.

NOTE: It is rather important to have a certain sound level in order to experience the full joy of the individual PlayAlive activities.

If you have been able to conduct the elements as described at section 9.2 - 9.3 the PlayAlive site has been successfully installed.

Thanks for your effort installing another PlayAlive product.

10.1 General introduction to PlayAlives Technology Platform

The PlayAlive system is an interactive system. The technology elements communicate with each other and thereby make it possible to realize activities for all ages.

The visible part of the installation is the “satellites”. The satellites are intelligent units that contain light, sound, touch sensor, and communication. They act as the user interface to the system. Cables connected to satellites supply them with power and communication.

IMPORTANT: BE CAREFUL WHEN HANDLING THE PARTS.

The PlayAlive technology elements are highly advanced electronics. Despite the fact that they are very robust after installation, they can easily be damaged before or during installation if not treated correctly.

NOTE: ALL PARTS ARE DESIGNED TO FIT TOGETHER WITHOUT THE NEED OF USING FORCE.

10.2 Conduit pipes and PlayAlive technology

When using flexible cable pipes it is important to ensure that the minimum bending radius complies too the following:

For our devicenet cables, we recommend 28/34 mm flexible cable pipe / conduit pipe with double walls for easy pulling of the cables.

Please note that low cost cable pipes are very soft and therefore very easy to bend in inappropriate radiuses – they are not recommended!

It is further recommended to place covers over the ends of the cable pipes during the period from installation of the pipes to installation of the electronics to avoid water in the pipes.

When installing the cable pipes it is recommended to ensure that care is taken to ensure that the pulling string in the pipes are kept available. It makes pulling the cables a lot easier. If this is not possible, then we recommend that you use vacuum (ex. a vacuum cleaner) to suck a pulling string through. It has proven easier than other methods. In some cases it is possible to push the cable through the pipes without other help. In cases where this is not possible, it is recommended to use a pulling string.

Please be aware that the PlayAlive cables are not designed to be pulled in the connectors. When pulling the cables please make sure that you pull the cable and not the connector.

10.3 Games

Please see the instructions for the different games below:

E-tennis	Beat your best friend in a game of E-tennis. The game is adaptive and will adjust speed to the level of the players. Serve the first "ball" by touching the flashing satellite out at the field. The ball is now sent over to the opponent's court and the game is on.
Mind Match	Find the identical pattern among the satellites out in the field. Will get more and more difficult for the players.
Stop watch	Use the outer running lane for a fun and motivating running game. Hit as many satellites as possible within 30 seconds. See your score at the end of the game.
Hot & Cold	Two persons or two teams play each other. One team chases the red satellites and the other chases blue satellites. The team who hits the most satellites during 30 seconds will win. High energy, fun and competition – A simple and fun game.
Free Play / Idle Mode	Each satellite will have its own play mode with Funny sounds and light creation. Will cease when games are started.

Additional games can be ordered at [PlayAlive](#).

11.1 Electrical specifications

Conventional power supply:	Astrodyne PMK320S-24E, 320W
Input voltage range:	90-264 V AC
Frequency range:	47-63Hz
Output voltage:	24 V DC
Power consumption (only PSU)	2 watt
Sensor satellite:	24V DC / power consumption when active 3 watt

System goes to sleep when no games are played

11.2 Average daily consumption for full system

	Speed	Infinity	Spider12	Spider16	e-Wall
1 hour play per day /23 h sleep mode (watt)	96	117	112	133	80
2 hours play per day /22 h sleep mode(watt)	122	155	140	179	97
3 hours play per day /21 h sleep mode(watt)	148	192	181	226	115

11.3 Maintenance

Minimum maintenance is required. Clean metal posts if needed.

- Check games are running correctly minimum once a year.
- Check LED lights and loud speakers are working minimum once a year.

If games or electronic is not working correctly please contact the local product supplier.